

## INDUSTRIAL DIESEL ENGINE

### Kubota V3 Series (4-Cylinder)

# V3800-T1E5H



#### Rated Power

## 96.4 kW @ 2400 rpm

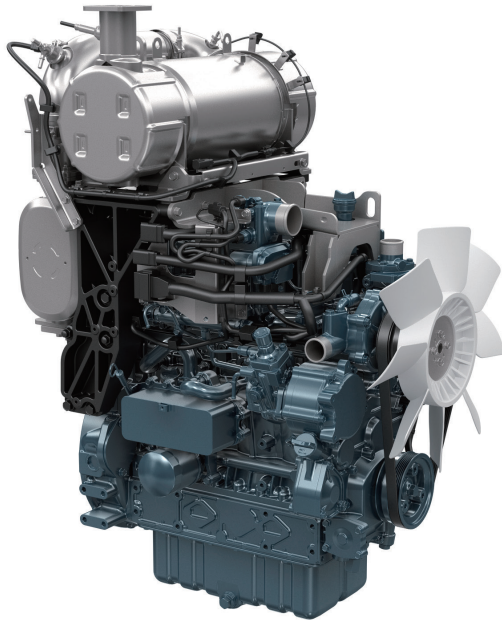

Photograph may show non-standard equipment.

#### Performance Curves

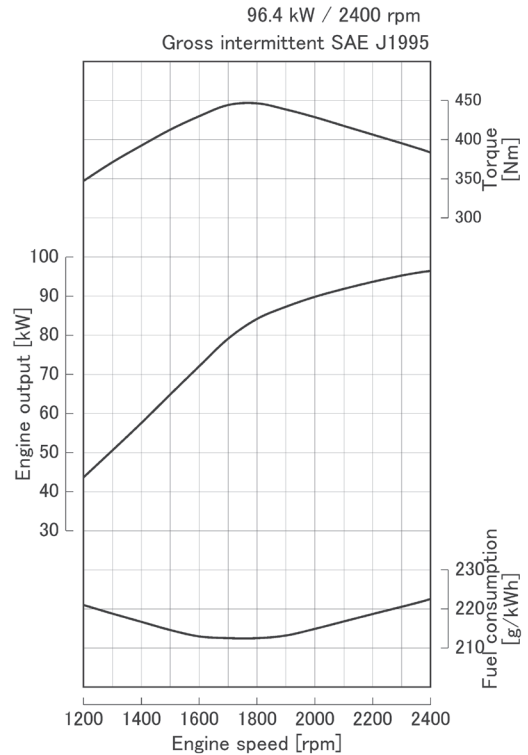

## Features and Benefits

### Proven Reliability and Technology

The latest technology and strong performance—two things customers expect from Kubota engines. We continue to provide both through the pursuit of excellence in emissions compliance and progress toward fully electronic controlled engines. These key areas allow Kubota to offer flexibility in the products and services we provide to customers worldwide.

### Emissions Compliance

Meeting rigid emissions regulations can be a challenge for any company. Our Kubota V3 Series engines have been designed to comply with various emissions regulations, including the stringent regulations: EPA/CARB Tier 4 and EU Stage V. In addition, innovative and reliable aftertreatment solutions, such as Diesel Particulate Filters (DPF) unit, have been applied to it.

### Advanced DPF Technology

Diesel Particulate Filters (DPF) are essential to comply EPA/CARB Tier 4 and EU Stage V emission regulations. With many years of experience in DPF engines, Kubota has developed a DPF technology that enables automatic regeneration even at a low rpm, giving your product a competitive edge.

The technology has also made long service intervals possible, helping to minimize downtime and maintenance worries.

### Fuel Efficiency

With Kubota's technology and experience, Common Rail System (CRS) is optimized and realizing low fuel consumption.

### Flexibility

Flexibility is a must when working with customers in different countries who have different engine needs. Since Kubota V3 Series engines have evolved along every step in meeting the requirements of each EPA Tier, we are able to provide our customers worldwide with engines certified for the appropriate emissions regulations. In addition, we have designed aftertreatment units with minimum impact for easy installation.

# V3800-TIE5H

## Engine Specifications

<b>Engine model</b>		V3800-TIE5H
<b>Emission regulation</b>		EPA/CARB Tier 4 + EU Stage V
<b>Type</b>		Vertical, water cooled 4-cycle DI diesel engine
<b>Cylinders</b>		4
<b>Bore and Stroke</b>	mm (in)	100.0 × 120.0 (3.937 × 4.724)
<b>Displacement</b>	L (cu.in)	3.769 (230.0)
<b>Aspiration</b>		Turbocharged + Turbo After Cooler
<b>Aftertreatment</b>		DOC + DPF + SCR
<b>Rated output / speed</b> *1	kW (HP) / rpm	96.4 (129.3) / 2400
<b>Maximum torque / speed</b> *1	Nm (lb-ft) / rpm	446.6 (329.4) / 1800
<b>Combustion system</b>		Direct Injection
<b>Fuel system</b>		Common Rail System
<b>EGR</b>		External EGR
<b>Length × Width × Height</b> *2 (without aftertreatment unit)	mm (in)	720 × 617 × 872 (28.3 × 24.3 × 34.3)
<b>Length × Width × Height</b> *3 (with aftertreatment unit)	mm (in)	864 × 638 × 1226 (34.0 × 25.1 × 48.26)
<b>Dry weight</b> *2	kg (lb)	423 (933)

Specifications are subject to change without prior notice.  
Dimensions and dry weight are according to Kubota's standard specification.  
Dimensions and weight depend on completed specifications.

\*1: SAE J1995 gross intermittent

\*2: Exclude cooling fan and exclude aftertreatment unit

\*3: Exclude cooling fan and include aftertreatment unit on engine

## Dimensions

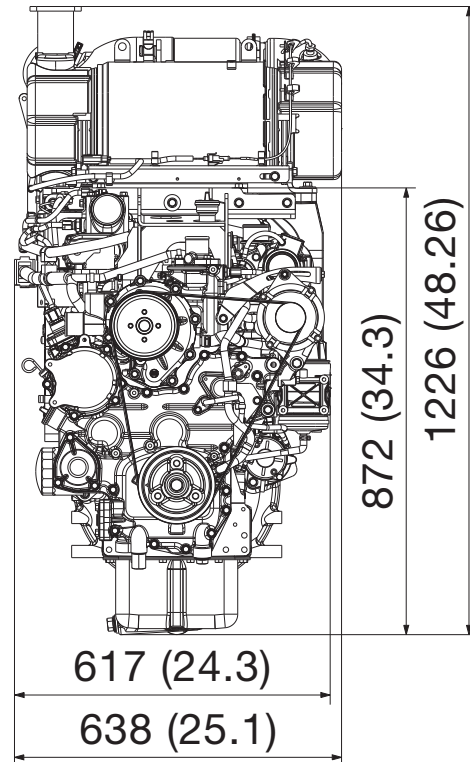
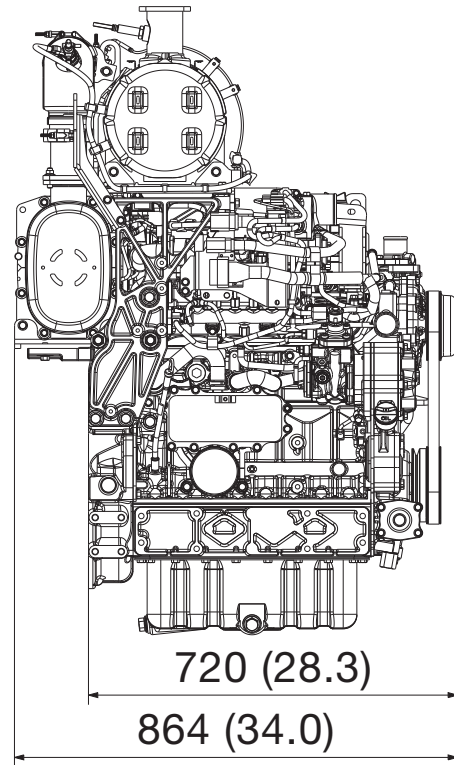

## Kubota Corporation

2-47, Shikitsuhigshi 1-chome Naniwa-ku, Osaka, 556-8601 Japan

<https://engine.kubota.com/en>

ASP-V3800-TIE5H2404-R2-8-218100