

DIESEL ENGINE FOR GENERATOR

Kubota 05 Series (4-Cylinder)

V1505-E4-BG2



Stand-by Power

12.5 kW @ 1500 rpm

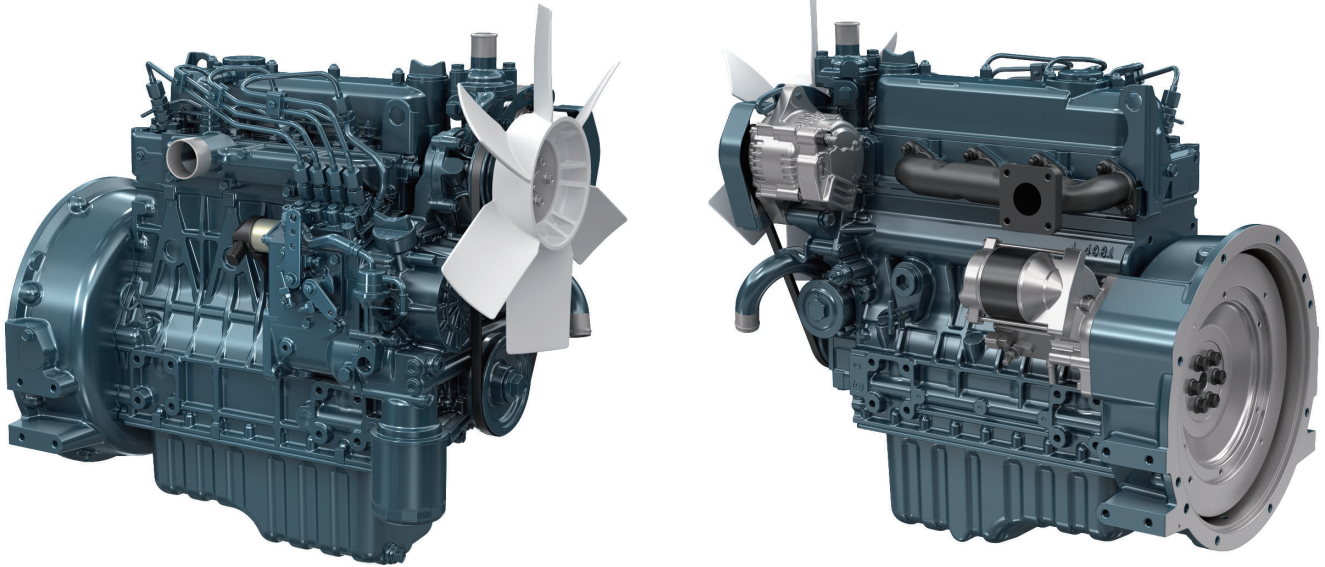

Photograph may show non-standard equipment.

Features and Benefits

Emissions Compliance

Meeting rigid emissions regulations can be a challenge for any company. Our Kubota 05 Series engines have been designed to comply with various emissions regulations, including the stringent regulation: EU Stage V.

Durable Power

The Kubota 05 Series is an established leader in its horsepower range, selected as the power source of choice by various industrial equipment manufacturers.

Clean and Quiet Power

The combustion chamber of Kubota's original E-TVCS (Three Vortex Combustion System) and piston recess have been optimized to achieve lower particulate matter (PM) levels.

For Earth, For Life

V1505-E4-BG2

Engine Specifications

Engine model		V1505-E4-BG2
Emission regulation		EU Stage V
Type		Vertical, water cooled 4-cycle diesel engine
Cylinders		4
Bore and Stroke	mm (in)	78.0 × 78.4 (3.07 × 3.09)
Displacement	L (cu.in)	1.498 (91.41)
Aspiration		Naturally aspirated
Aftertreatment		—
Net stand-by power *1	kW (HP) / rpm	12.5 (16.8) / 1500
Net continuous power *1	kW (HP) / rpm	11.1 (14.9) / 1500
Combustion system		Indirect Injection
Fuel system		In-line pump
Length x Width x Height *2 (without aftertreatment unit)	mm (in)	602 × 398 × 607 (23.7 × 15.7 × 23.9)
Dry weight *2	kg (lb)	127 (280)

Specifications are subject to change without prior notice.
Dimensions and dry weight are according to Kubota's standard specification.
Dimensions and weight depend on completed specifications.

*1: SAE J1349

*2: Exclude cooling fan

Dimensions

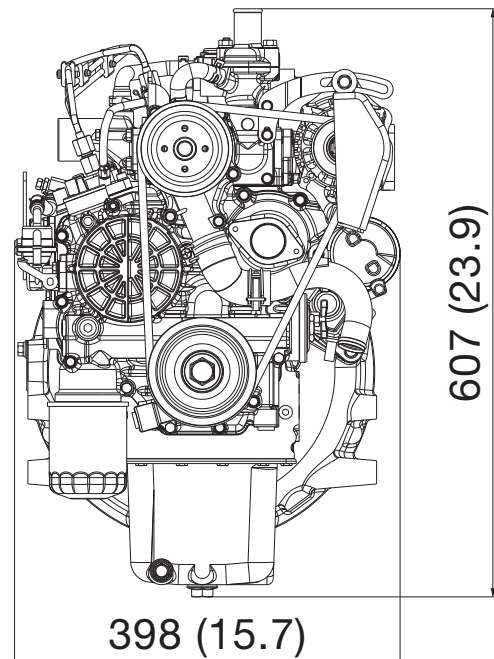
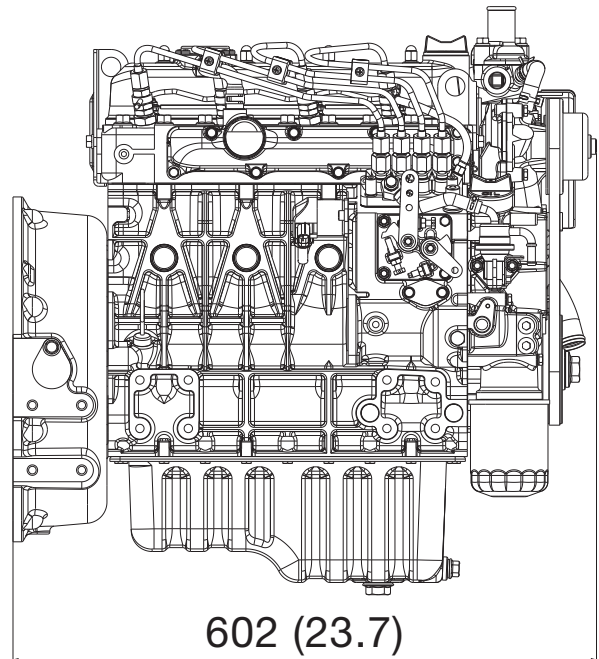

Kubota Corporation

2-47, Shikitsuhigshi 1-chome Naniwa-ku, Osaka, 556-8601 Japan

<https://global.engine.kubota.co.jp/en/>

ASP-V1505-E4-BG22110-N0-STD-208098