

## INDUSTRIAL DIESEL ENGINE

### Kubota EA series (1-Cylinder)

# EA330-E4

EPA/CARB  
TIER  
4

#### Rated Power

## 5.15 kW @ 3000 rpm



Photograph may show non-standard equipment.

#### Performance Curves

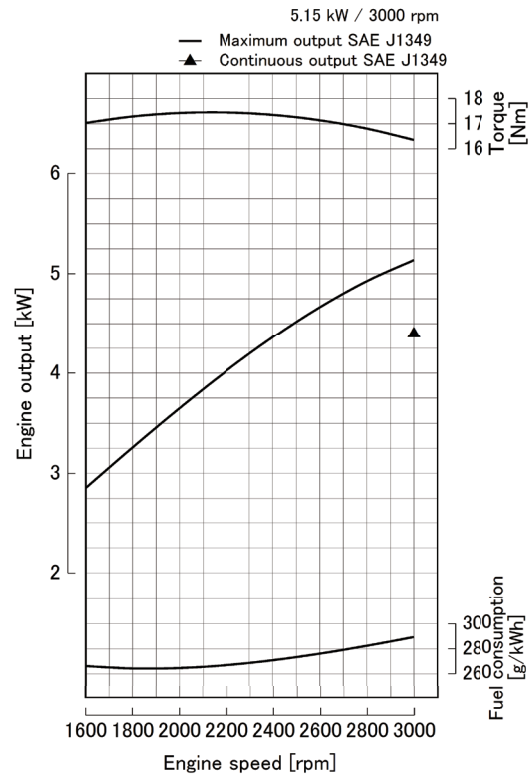

#### Features and Benefits

##### Emissions

The Kubota EA330 engine complies with EPA Tier 4 emissions regulations. These are the most stringent emissions regulations in the world in this class. Kubota engine less than 19 kW also meets emission standards over the NRTC and the NTE requirements.

##### Durable Power

The Kubota EA330 engine has been chosen as the power source for a variety of applications.

Combustion chamber with TVCS (Three Vortex Combustion System) provides stable performance even at high engine rpm. With the extra displacement for its output, work goes surely and steadily. This engine offers a seamless transition from E2 to E4 by entirely maintaining the same performance and physical characteristics.

##### Clean and Quiet Power

Kubota's original TVCS (Three Vortex Combustion System) provides ideal mixture of air and fuel, and enables low fuel consumption.

For Earth, For Life  
**Kubota**

# EA330-E4

## Engine Specifications

<b>Engine model</b>	EA330-E4	
<b>Emission regulation</b>	EPA/CARB Tier 4 (NRTC/NTE test mode)	
<b>Type</b>	Horizontal, water cooled 4-cycle diesel engine	
<b>Cylinders</b>	1	
<b>Bore and stroke</b>	mm (in)	77.0 x 70.0 (3.03 x 2.76)
<b>Displacement</b>	L (cu.in)	0.325 (19.8)
<b>Maximum output / speed</b> *1	kW (HP) / rpm	5.15 (6.91) / 3000
<b>Continuous output / speed</b> *1	kW (HP) / rpm	4.4 (5.9) / 3000
<b>Maximum torque / speed</b>	Nm (lb-ft) / rpm	17.65 (13.02) / 2000
<b>Combustion system</b>	Indirect Injection *2	
<b>Fuel tank capacity</b>	L (U.S.gal)	4.8 (1.3)
<b>Lubricating oil capacity</b>	L (U.S.gal)	1.3 (0.34)
<b>Starter capacity</b>	V-kW	12-1.1
<b>Charging dynamo</b>	V-W	12-60
<b>Length x Width x Height</b>	mm (in)	312 x 566 x 457 (12.3 x 22.3 x 18.0)
<b>Dry weight</b> *2	kg (lbs)	54 (120)

Specification is subject to change without notice.  
 Dry weight is according to Kubota's standard specification.  
 When specification varies, the weight will vary accordingly.

\*1: SAE J1349 net intermittent

\*2: Three Vortex Combustion System (TVCS)

## Dimensions

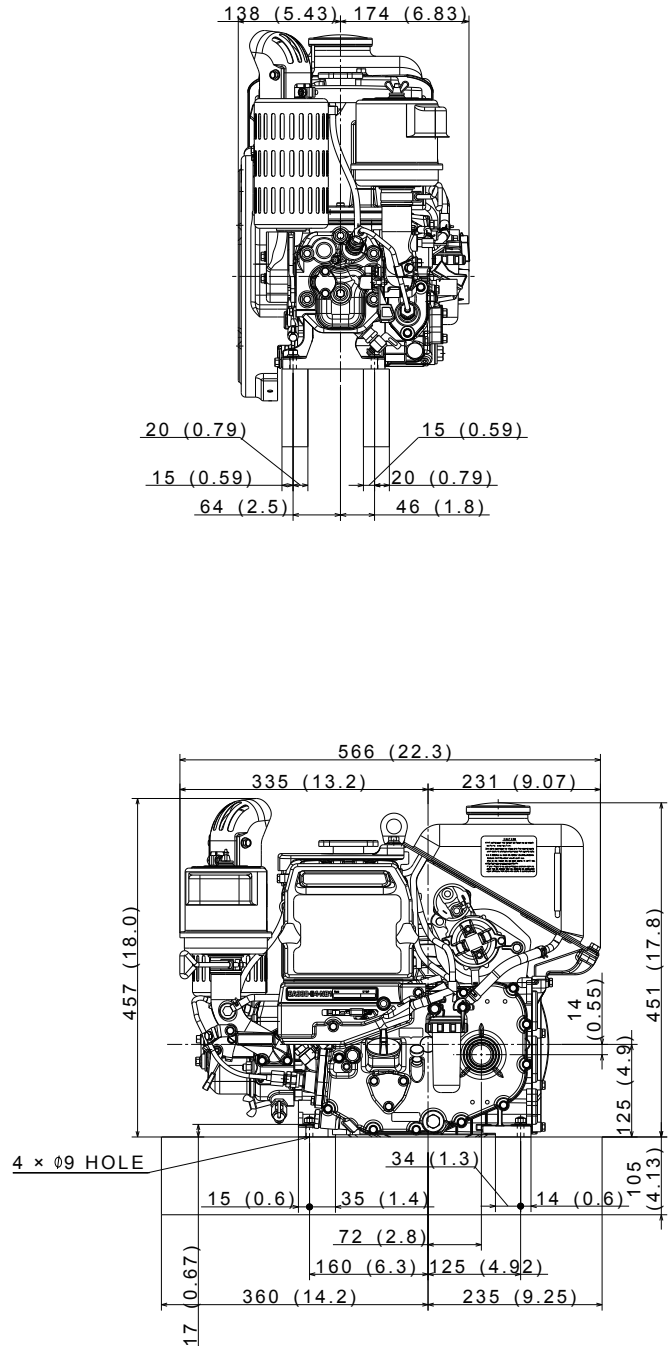

## Kubota Corporation

2-47, Shikitsuhigashi 1-chome Naniwa-ku, Osaka, 556-8601 Japan

<https://global.engine.kubota.co.jp/en/>

ASP-EA330-E42404-R3-8-208098

