

## INDUSTRIAL DIESEL ENGINE

### Kubota OC Series (1-Cylinder)

# OC95-E4



#### Rated Power

## 7.0 kW @ 3600 rpm



Photograph may show non-standard equipment.

#### Performance Curves

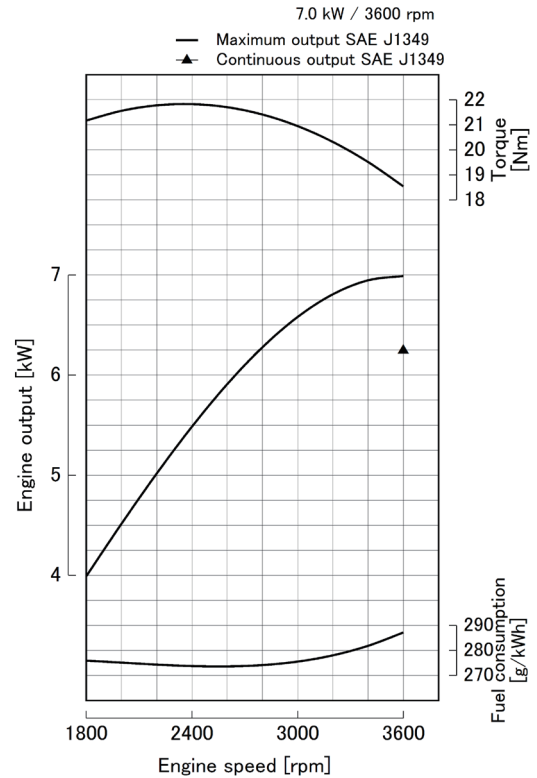

#### Features and Benefits

##### Emissions

The Kubota OC95 engine complies with EPA Tier 4 emissions regulations. These are the most stringent emissions regulations in the world in this class. Kubota engine less than 19 kW also meets emission standards over the NRTC and the NTE requirements.

##### Durable Power

This engine offers a seamless transition from E2 to E4 by totally maintaining the same performance and physical characteristics.

##### Clean and Quiet Power

The Kubota OC series is a unique engine that has light-weight and compact features of an air-cooled engine together with the low noise, durability and clean exhaust emission of a water-cooled diesel engine. With ACTV (Advanced Cooling Three Vortex) system, the cylinder block is air-cooled, whereas the combustion area of the cylinder head is oil-cooled.

For Earth, For Life  
**Kubota**

# OC95-E4

## Engine Specifications

<b>Engine model</b>		OC95-E4
<b>Emission regulation</b>		EPA/CARB Tier 4 (NRTC/NTE test mode) + EU Stage V
<b>Type</b>		Vertical, liquid-cooled 4-cycle diesel engine
<b>Cylinders</b>		1
<b>Bore and stroke</b>	mm (in)	83.0 x 77.0 (3.27 x 3.03)
<b>Displacement</b>	L (cu.in)	0.416 (25.4)
<b>Maximum output / speed</b> *1	kW (HP) / rpm	7.0 (9.4) / 3600
<b>Continuous output / speed</b> *1	kW (HP) / rpm	6.25 (8.38) / 3600
<b>Maximum torque / speed</b>	Nm (lb-ft) / rpm	21.6 (15.9) / 2300
<b>Combustion system</b>		Indirect Injection *2
<b>Fuel tank capacity</b>	L (U.S.gal)	5.5 (1.5)
<b>Lubricating oil capacity</b>	L (U.S.gal)	1.7 (0.45)
<b>Starter capacity</b>	V-kW	12-1.2
<b>Charging dynamo</b>	V-W	12-48 (L1 model: 12-170)
<b>Length x Width x Height</b>	mm (in)	451 x 503 x 501 (17.8 x 19.8 x 19.7)
<b>Dry weight</b> *2	kg (lbs)	56 (120)

Specification is subject to change without notice.  
 Dry weight is according to Kubota's standard specification.  
 When specification varies, the weight will vary accordingly.

\*1: SAE J1349 net intermittent  
 \*2: Three Vortex Combustion System (TVCS)

## Dimensions

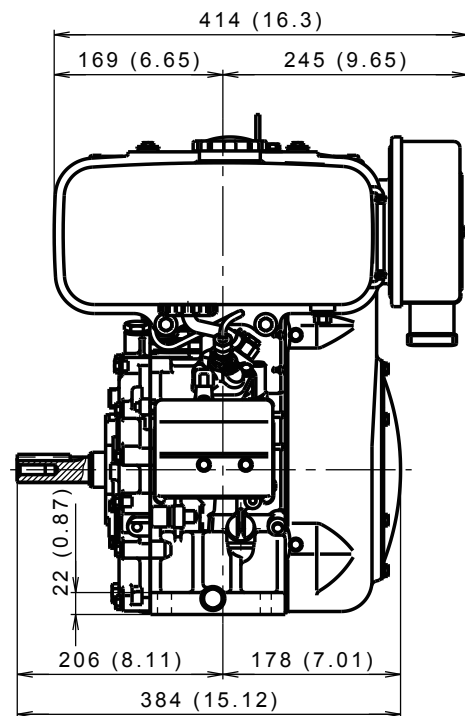
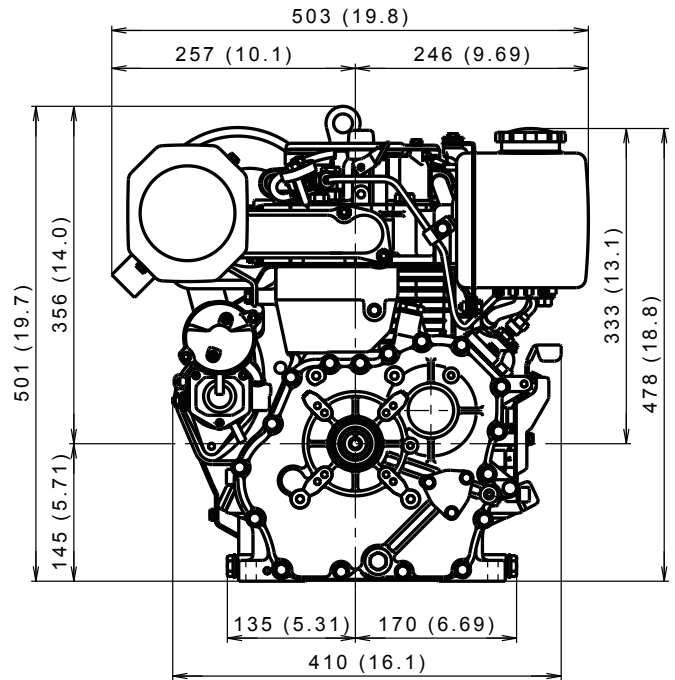

## Kubota Corporation

2-47, Shikitsuhigashi 1-chome Naniwa-ku, Osaka, 556-8601 Japan  
<https://global.engine.kubota.co.jp/en/>

ASPOC95-E41902-R1-I-178040

# OC95

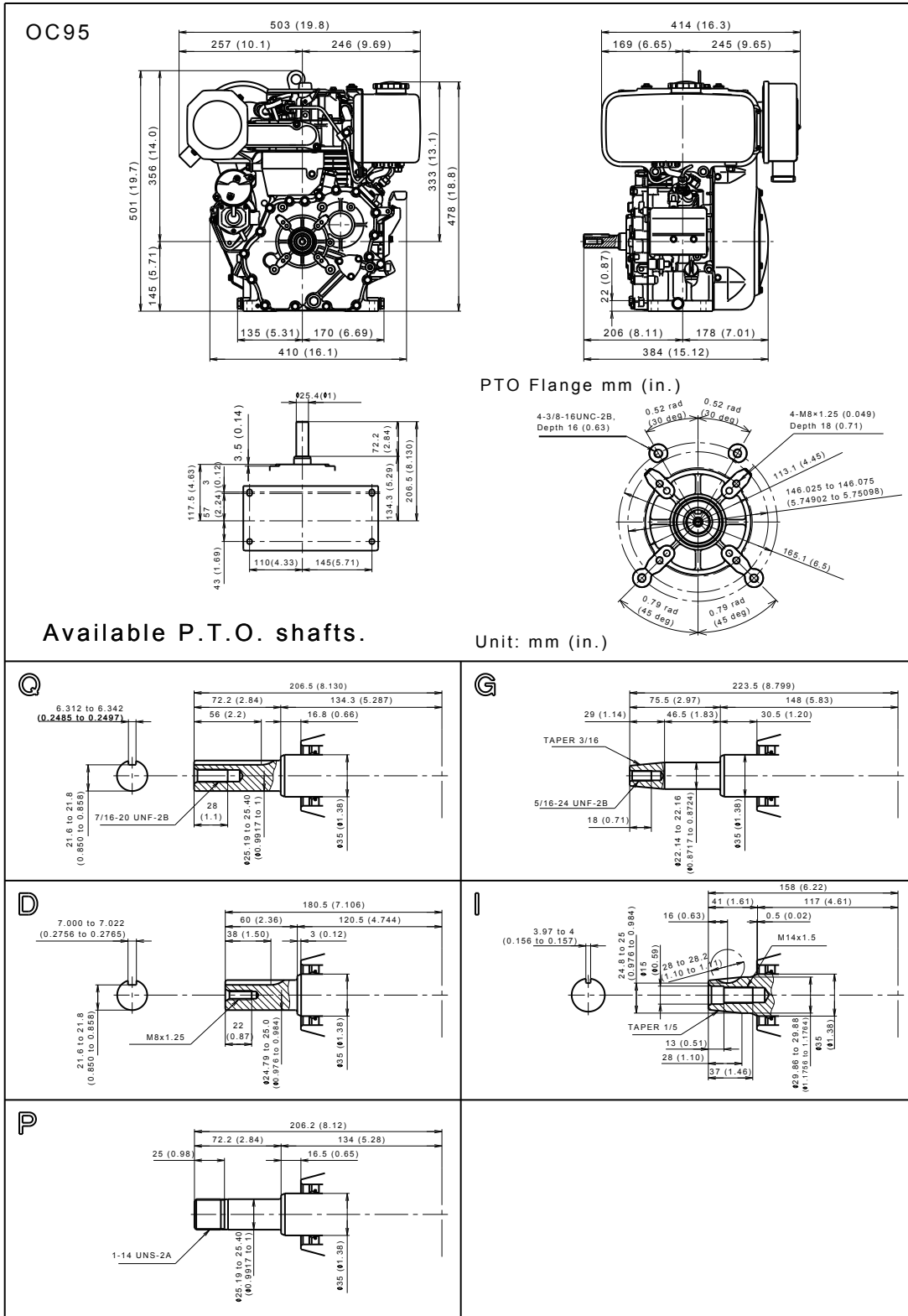

**Kubota Corporation**

2-47, Shikitsu Higashi 1-chome Naniwa-ku, Osaka, 556-8601 Japan

<https://global.engine.kubota.co.jp/en/>

ASPOC95-E41902-R1-I-178040