

DIESEL ENGINE FOR GENERATOR

Kubota 03 Series (4-Cylinder)

V2403-M-DI-BG

Stand-by Power

22.4 kW @ 1500 rpm / 26.6 kW @ 1800 rpm

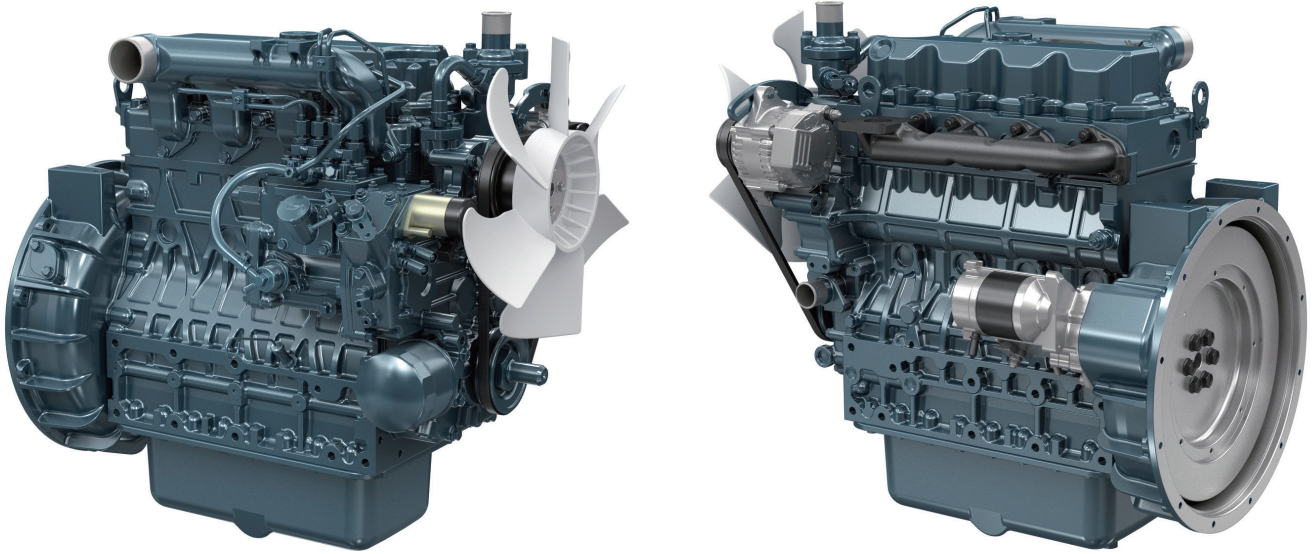

Photograph may show non-standard equipment.

Features and Benefits

Durable Power

The Kubota 03-M Series is well known for its industrial applications. With numerous features such as a built-in solenoid, low fan position, and single-side serviceability, this engine provides excellent performance and flexibility. The cooling water passages between the cylinder bores features Kubota's original casting technology as a countermeasure against the heat load caused by high power density, providing both superior endurance and reliable engine performance.

For Earth, For Life
Kubota

V2403-M-DI-BG

Engine Specifications

Engine model		V2403-M-DI-BG
Emission regulation		-
Type		Vertical, water cooled 4-cycle DI diesel engine
Cylinders		4
Bore and Stroke	mm (in)	87.0 × 102.4 (3.43 × 4.031)
	L (cu.in)	2.434 (148.5)
Aspiration		Naturally Aspirated
Aftertreatment		-
Net stand-by power *1	kW (HP) / rpm	22.4 (30.0) / 1500 26.6 (35.7) / 1800
	kW (HP) / rpm	20.9 (28.0) / 1500 24.8 (33.3) / 1800
Combustion system		Direct Injection
Fuel system		In-line pump
EGR		-
Length × Width × Height *2 (without aftertreatment unit)	mm (in)	669 × 490 × 683 (26.3 × 19.3 × 26.9)
	kg (lb)	204 (450)

Specifications are subject to change without prior notice.
Dimensions and dry weight are according to Kubota's standard specification.
Dimensions and weight depend on completed specifications.

*1: SAE J1349

*2: Exclude cooling fan

Dimensions

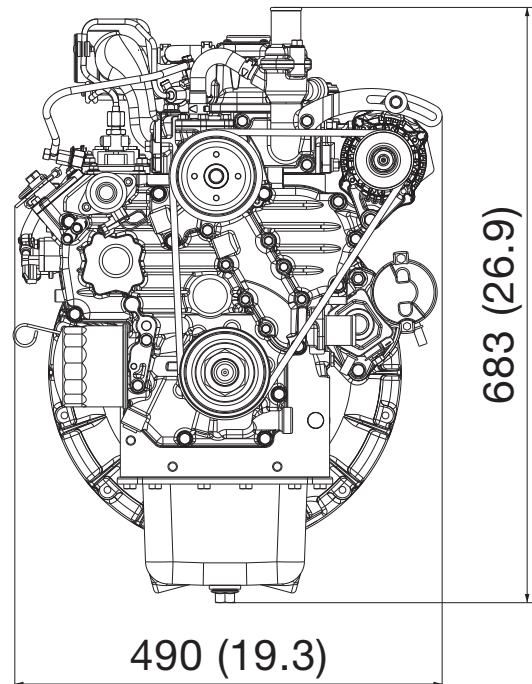
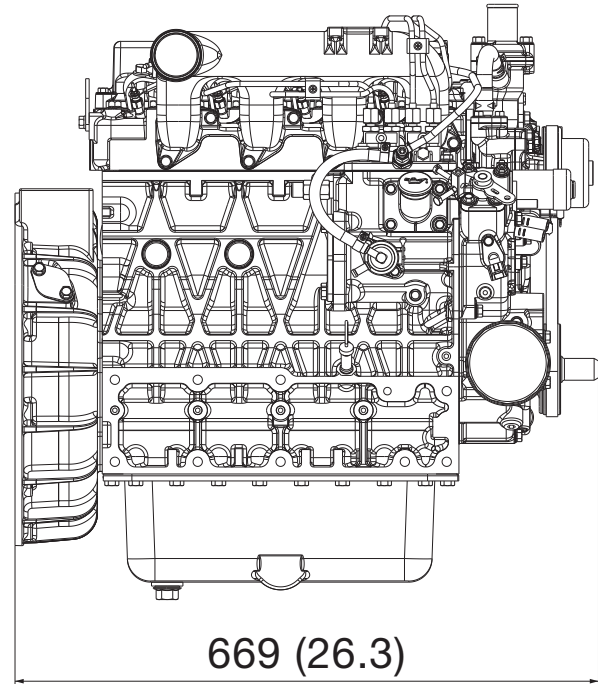

Kubota Corporation

2-47, Shikitsuhigshi 1-chome Naniwa-ku, Osaka, 556-8601 Japan

<https://global.engine.kubota.co.jp/en>

ASP-V2403-M-DI-BG2404-N0-STD-208098